

CSE 250

Data Structures

Dr. Eric Mikida
epmikida@buffalo.edu

Dr. Oliver Kennedy
okennedy@buffalo.edu

212 Capen Hall

Day 16
Introduction to Graphs
Textbook Ch. 15.3

Announcements

- Testing phase of PA2 due Monday 10/10
 - Autograder has been recently updated to address some issues

Recap

Mazes!

Formalizing Maze-Solving

Inputs:

- The map: an $n \times m$ grid of squares which are either filled or empty
- The **O** is at position *start*
- The **X** is at position *dest*

Goal: Compute $\text{steps}(\text{start}, \text{dest})$, the minimum number of steps from start to end.

How do we define the steps function?

Mazes

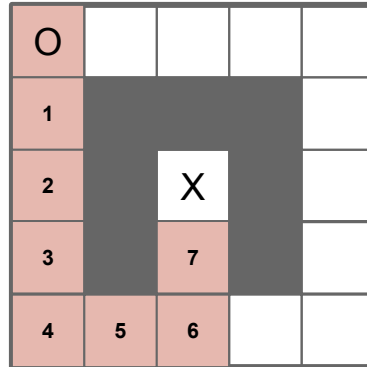

Mazes: Now with...Stacks!

```
steps(pos, dest, visited):  
    if pos == dest then return visited.copy()  
    elif pos ∈ visited then return no_path  
    elif is_filled(pos) then return no_path  
    else  
        visited.push(pos)  
        bestPath = 1 + min of all 4 steps  
        visited.pop()  
        return bestPath
```

Mazes: Now with...Stacks!

```
steps(pos, dest, visited):
```

```
    if pos == dest then return visited.copy()
```

```
    elif pos ∈ visited then return no_path
```

```
    elif is_filled(pos) then return no_path
```

```
    else
```

```
        visited.push(pos)
```

```
        bestPath = 1 + min of all 4 steps
```

```
        visited.pop()
```

```
    return bestPath
```

We can use stacks to track where we have been!

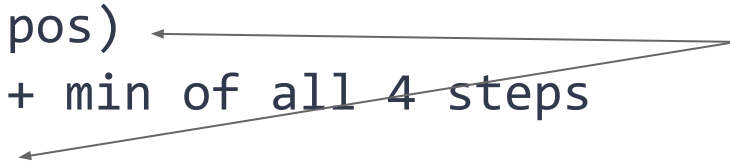

Queues?

Thought Experiment: Can we do something similar with queues?

Queues?

Thought Experiment: Can we do something similar with queues?

Hold that thought!

Let's Talk About Graphs

A **graph** is a pair (V,E) where:

- V is a set of **vertices**
- E is a set of vertex pairs called **edges**
- Edges and vertices may also store data (**labels**)

Graphs

Example: A social network

(nodes store users, pictures, tweets, etc)

(edges store interactions)

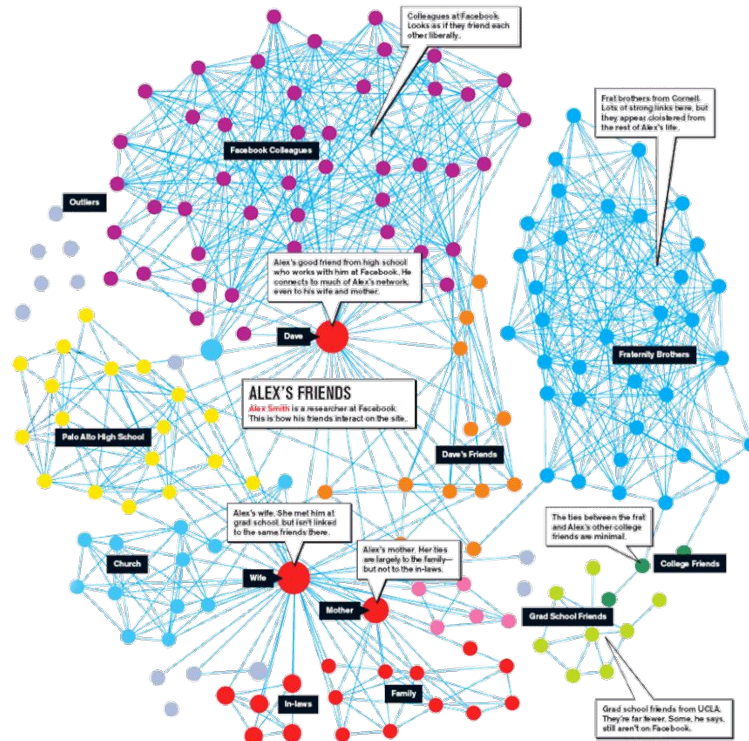

Graphs

Example: A computer network
(edges store ping, nodes store addresses)

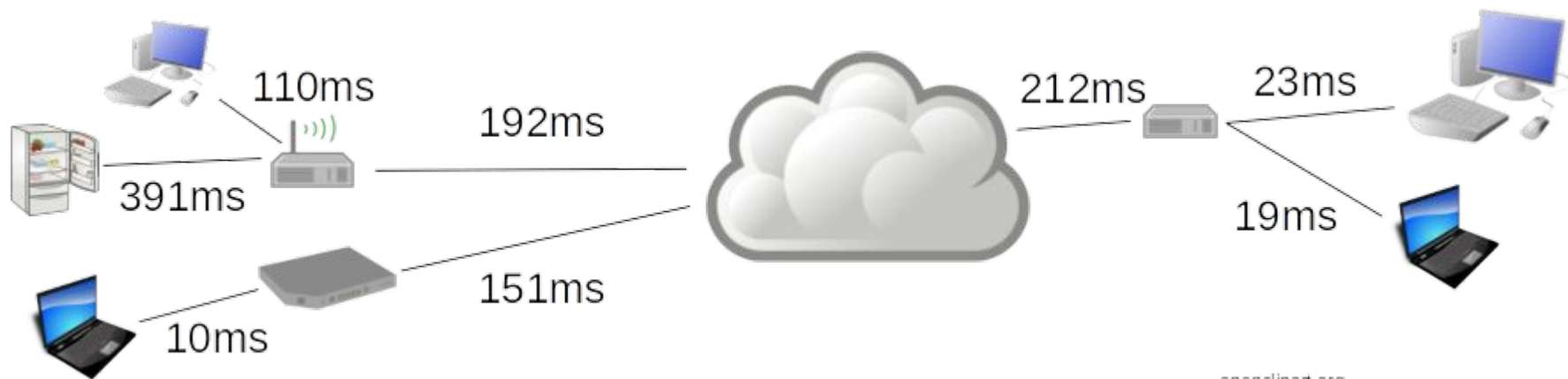

Edge Types

Directed Edge (asymmetric relationship)

- Ordered pair of vertices (u, v)
- origin (u) \rightarrow destination (v)

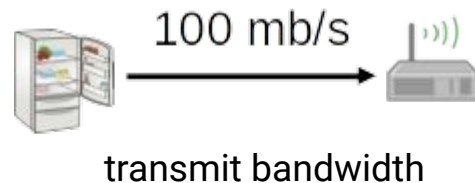

Undirected Edge (symmetric relationship)

- Unordered pair of vertices (u, v)

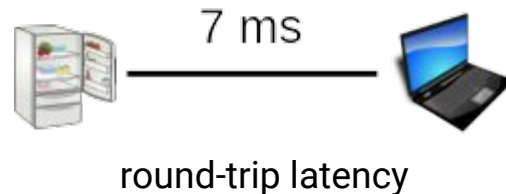

Edge Types

Directed Edge (asymmetric relationship)

- Ordered pair of vertices (u, v)
- origin (u) \rightarrow destination (v)

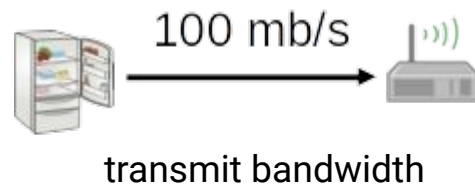

Undirected Edge (symmetric relationship)

- Unordered pair of vertices (u, v)

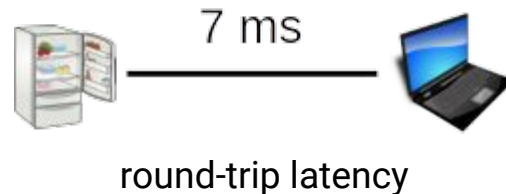

Directed Graph: All edges are directed

Undirected Graph: All edges are undirected

Applications

- Transportation (flight/road/rail routing)
- Protein/Protein Interactions
- Computer Networks (ie the internet)
- Social Networks
- Dependency Tracking (ie make)
- Taxonomies

Terminology

Endpoints of an edge

U, V are endpoints of a

Adjacent Vertices

U, V are adjacent

Degree of a vertex

X has degree 5

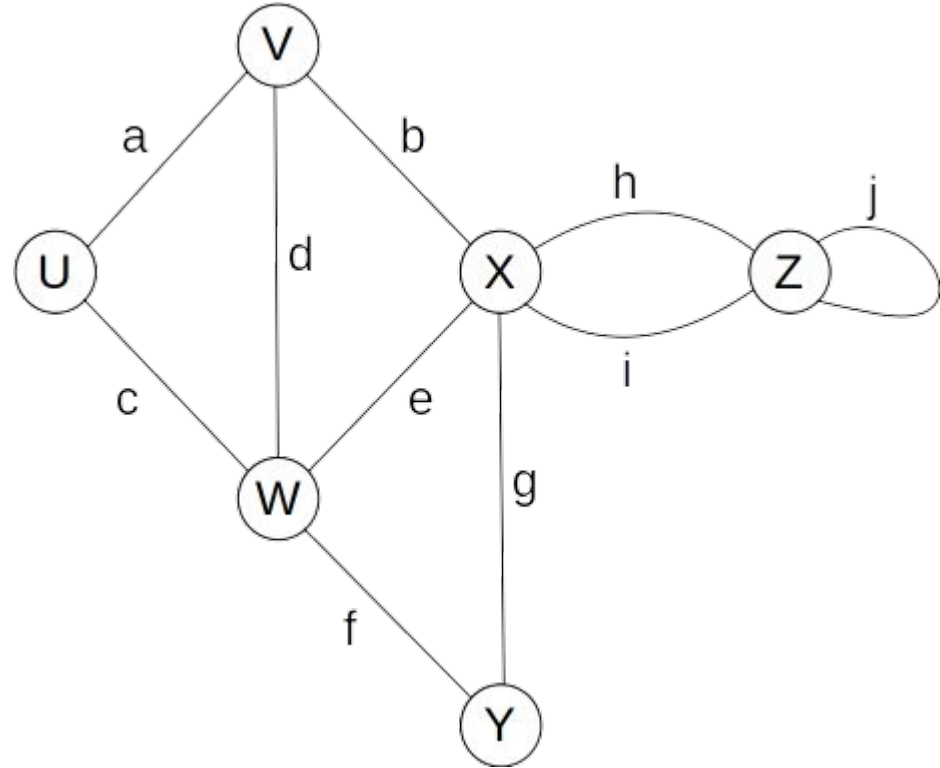

Terminology

Edges incident on a vertex

a, b, d are incident on *V*

Parallel Edges

h, i are parallel

Self-Loop

j is a self-loop

Simple Graph

A graph without parallel edges or self-loops

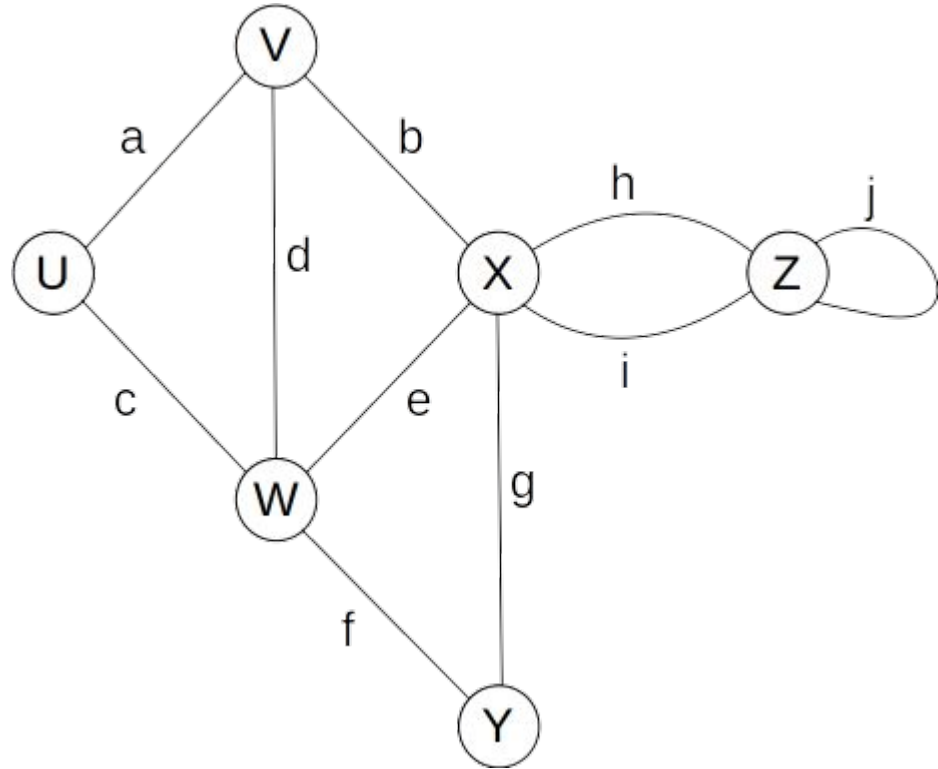

Terminology

Path

A sequence of alternating vertices and edges

- begins with a vertex
- ends with a vertex
- each edge preceded/followed by its endpoints

Simple Path

A path such that all of its vertices and edges are distinct

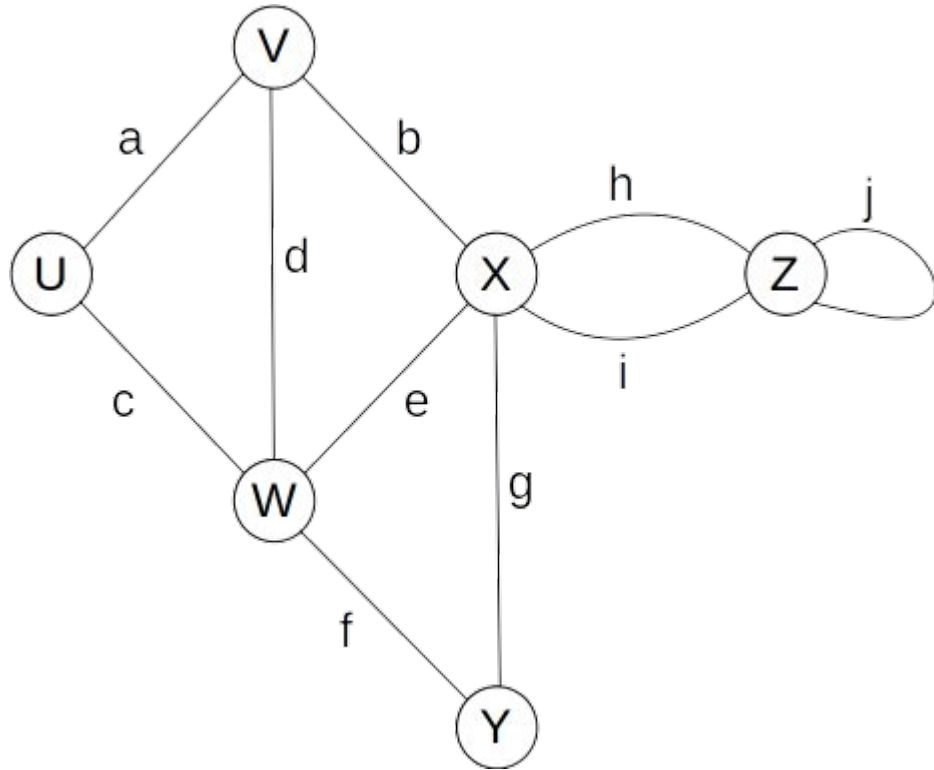

Terminology

Path

A sequence of alternating vertices and edges

- begins with a vertex
- ends with a vertex
- each edge preceded/followed by its endpoints

Simple Path

A path such that all of its vertices and edges are distinct

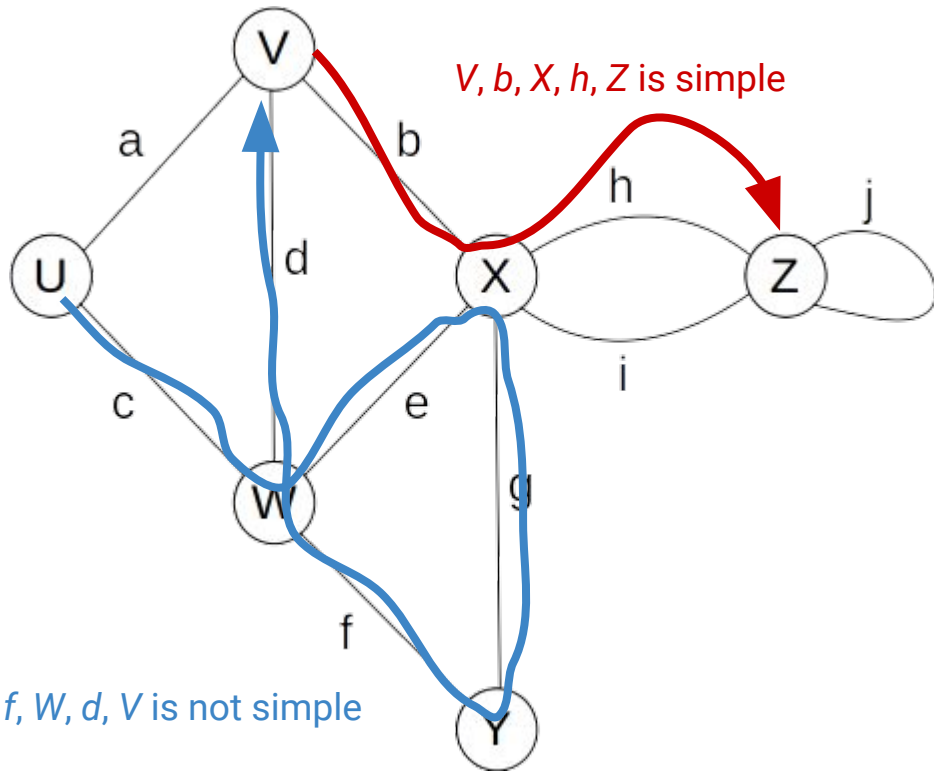

Terminology

Cycle

A path that begins and ends with the same vertex. Must contain at least one edge

Simple Cycle

A cycle such that all of its vertices and edges are distinct

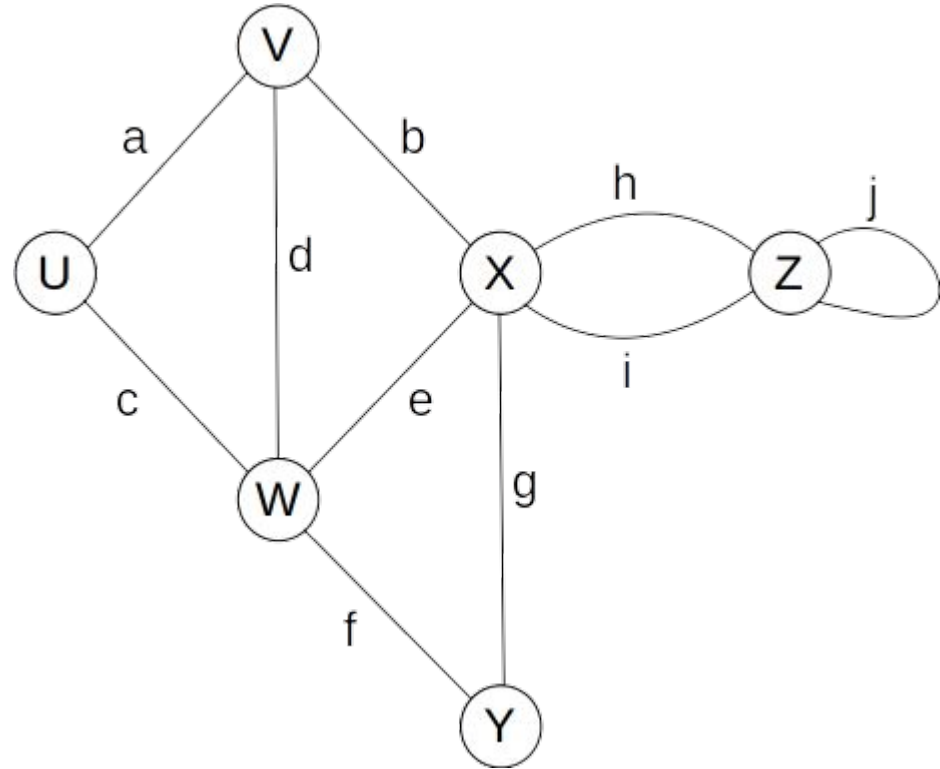

Terminology

Cycle

A path that begins and ends with the same vertex. Must contain at least one edge

Simple Cycle

A cycle such that all of its vertices and edges are distinct

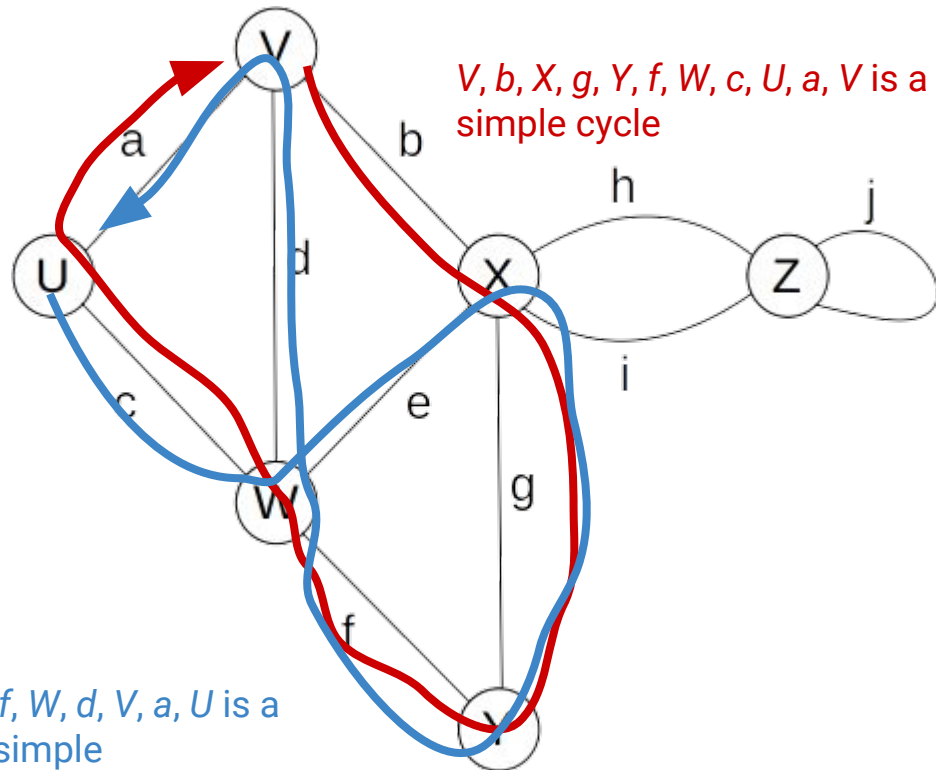

Notation

n The number of vertices

m The number of edges

$\text{deg}(v)$ The degree of vertex **v**

Graph Properties

$$\sum_v \deg(v) = 2m$$

Graph Properties

$$\sum_v \deg(v) = 2m$$

Proof: Each edge is counted twice

Graph Properties

In a directed graph with no self-loops and no parallel edges:

$$m \leq n(n - 1)$$

Graph Properties

In a directed graph with no self-loops and no parallel edges:

$$m \leq n(n - 1)$$

No parallel edges: each pair is connected at most once

No self-loops: pick each vertex only once

Graph Properties

In a directed graph with no self-loops and no parallel edges:

$$m \leq n(n - 1)$$

No parallel edges: each pair is connected at most once

No self-loops: pick each vertex only once

n choices for the first vertex; $(n - 1)$ choices for the second vertex.
Therefore even if there was one edge between every possible pair, we still
have at most $n(n - 1)$ edges

A (Directed Graph) ADT

Two type parameters (Graph[V, E])

V: The vertex label type

E: The edge label type

Vertices

...are elements (like Linked List Nodes)

...store a value of type **V**

Edges

...are also elements

...store a value of type **E**

A (Directed) Graph ADT

```
trait Graph[V, E] {  
  def vertices: Iterator[Vertex]  
  def edges: Iterator[Edge]  
  def addVertex(label: V): Vertex  
  def addEdge(orig: Vertex, dest: Vertex, label: E): Edge  
  def removeVertex(vertex: Vertex): Unit  
  def removeEdge(edge: Edge): Unit  
}
```

A (Directed) Graph ADT

```
trait Vertex[V, E] {  
  def outEdges: Seq[Edge]  
  def inEdges: Seq[Edge]  
  def incidentEdges: Iterator[Edge] = outEdges ++ inEdges  
  def edgeTo(v: Vertex): Boolean  
  def label: V  
}
```

```
trait Edge[V, E] {  
  def origin: Vertex  
  def destination: Vertex  
  def label: E  
}
```

Attempt 1: Edge List

Data Model:

A List of Edges

(ArrayBuffer)

A List of Vertices

(ArrayBuffer)

Attempt 1: Edge List

```
class DirectedGraphV1[V, E] extends Graph[V, E] {  
  val vertices = mutable.Buffer[Vertex]()  
  val edges    = mutable.Buffer[Edge]()  
  
  /* ... */  
}
```

Attempt 1: Edge List

```
def addVertex(label: V): Vertex =  
    vertices.append(new Vertex(label))
```

What's the complexity?

Attempt 1: Edge List

```
def addVertex(label: V): Vertex =  
    vertices.append(new Vertex(label))
```

What's the complexity?

```
def addEdge(orig: Vertex, dest: Vertex, label: E): Edge =  
    edges.append(new Edge(orig, dest, label))
```

What's the complexity?

Attempt 1: Edge List

```
def addVertex(label: V): Vertex =  
    vertices.append(new Vertex(label))
```

What's the complexity? Amortized $O(1)$

```
def addEdge(orig: Vertex, dest: Vertex, label: E): Edge =  
    edges.append(new Edge(orig, dest, label))
```

What's the complexity? Amortized $O(1)$

Attempt 1: Edge List

```
def removeEdge(edge: Edge): Unit =  
    edges.subtractOne(edge)
```

What's the complexity?

Attempt 1: Edge List

```
def removeEdge(edge: Edge): Unit =  
    edges.subtractOne(edge)
```

What's the complexity? $O(n)$

Attempt 2: Linked Edge List

Data Model:

A List of Edges

(DoublyLinkedList)

A List of Vertices

(DoubleLinkedList)

Attempt 2: Linked Edge List

```
class DoublyLinkedList[T] extends Seq[T] {  
  def append(element: T): Node =  
    /* O(1) with tail pointer */  
  
  def remove(node: Node): Unit =  
    /* O(1) */  
  
  def iterator: Iterator[T]: Unit =  
    /* O(1) + O(1) per call to next */  
}
```

Attempt 2: Linked Edge List

```
class DirectedGraphV2[V, E] extends Graph[V, E] {  
  val vertices = DoublyLinkedList[Vertex]()  
  class Vertex(label: V) = {  
    var node: DoublyLinkedList[Vertex].Node = null  
    /* ... */  
  }  
  def addVertex(label: V): Vertex = {  
    val vertex = new Vertex(label)  
    val node = vertices.append(vertex)  
    vertex.node = node  
    return vertex  
  }  
  /* ... */  
}
```

Attempt 2: Linked Edge List

```
class DirectedGraphV2[V, E] extends Graph[V, E] {  
  val vertices = DoublyLinkedList[Vertex]()  
  class Vertex(label: V) = {  
    var node: DoublyLinkedList[Vertex].Node = null  
    /* ... */  
  }  
  def addVertex(label: V): Vertex = {  
    val vertex = new Vertex(label)  
    val node = vertices.append(vertex)  
    vertex.node = node  
    return vertex  
  }  
  /* ... */  
}
```

Add our vertex to the linked list, and store a reference to the list node

Attempt 2: Linked Edge List

```
class DirectedGraphV2[V, E] extends Graph[V, E] {  
  val vertices = DoublyLinkedList[Vertex]()  
  class Vertex(label: V) = {  
    var node: DoublyLinkedList[Vertex].Node = null  
    /* ... */  
  }  
  def addVertex(label: V): Vertex = {  
    val vertex = new Vertex(label)  
    val node = vertices.append(vertex)  
    vertex.node = node  
    return vertex  
  }  
  /* ... */  
}
```

Add our vertex to the linked list, and store a reference to the list node

What is the complexity?

Attempt 2: Linked Edge List

```
class DirectedGraphV2[V, E] extends Graph[V, E] {  
  val vertices = DoublyLinkedList[Vertex]()  
  class Vertex(label: V) = {  
    var node: DoublyLinkedList[Vertex].Node = null  
    /* ... */  
  }  
  def addVertex(label: V): Vertex = {  
    val vertex = new Vertex(label)  
    val node = vertices.append(vertex)  
    vertex.node = node  
    return vertex  
  }  
  /* ... */  
}
```

Add our vertex to the linked list, and store a reference to the list node

What is the complexity? $\Theta(1)$

Attempt 2: Linked Edge List

```
class DirectedGraphV2[V, E] extends Graph[V, E] {
  val edges = DoublyLinkedList[Edge]()
  class Edge(orig: Vertex, dest: Vertex, label: E) = {
    var node: DoublyLinkedList[Edge].Node = null
    /* ... */
  }
  def addEdge(orig: Vertex, dest: Vertex, label: E): Vertex = {
    val edge = new Edge(orig, dest, label)
    val node = edges.append(vertex)
    edge.node = node
    return edge
  }
  /* ... */
}
```

Attempt 2: Linked Edge List

```
class DirectedGraphV2[V, E] extends Graph[V, E] {  
  val edges = DoublyLinkedList[Edge]()  
  class Edge(orig: Vertex, dest: Vertex, label: E) = {  
    var node: DoublyLinkedList[Edge].Node = null  
    /* ... */  
  }  
  def addEdge(orig: Vertex, dest: Vertex, label: E): Vertex = {  
    val edge = new Edge(orig, dest, label)  
    val node = edges.append(vertex)  
    edge.node = node  
    return edge  
  }  
  /* ... */  
}
```

Add our edge to the linked list, and store a reference to the list node

Attempt 2: Linked Edge List

```
class DirectedGraphV2[V, E] extends Graph[V, E] {  
  val edges = DoublyLinkedList[Edge]()  
  class Edge(orig: Vertex, dest: Vertex, label: E) = {  
    var node: DoublyLinkedList[Edge].Node = null  
    /* ... */  
  }  
  def addEdge(orig: Vertex, dest: Vertex, label: E): Vertex = {  
    val edge = new Edge(orig, dest, label)  
    val node = edges.append(vertex)  
    edge.node = node  
    return edge  
  }  
  /* ... */  
}
```

Add our edge to the linked list, and store a reference to the list node

What is the complexity?

Attempt 2: Linked Edge List

```
class DirectedGraphV2[V, E] extends Graph[V, E] {  
  val edges = DoublyLinkedList[Edge]()  
  class Edge(orig: Vertex, dest: Vertex, label: E) = {  
    var node: DoublyLinkedList[Edge].Node = null  
    /* ... */  
  }  
  def addEdge(orig: Vertex, dest: Vertex, label: E): Vertex = {  
    val edge = new Edge(orig, dest, label)  
    val node = edges.append(vertex)  
    edge.node = node  
    return edge  
  }  
  /* ... */  
}
```

Add our edge to the linked list, and store a reference to the list node

What is the complexity? $\Theta(1)$

Attempt 2: Linked Edge List

```
class DirectedGraphV2[V, E] extends Graph[V, E] {  
  val edges = DoublyLinkedList[Edge]()  
  
  def removeEdge(edge: Edge): Unit = {  
    edges.remove(edge.node)  
  }  
  /* ... */  
}
```

Attempt 2: Linked Edge List

```
class DirectedGraphV2[V, E] extends Graph[V, E] {  
  val edges = DoublyLinkedList[Edge]()  
  
  def removeEdge(edge: Edge): Unit = {  
    edges.remove(edge.node)  
  }  
  /* ... */  
}
```

Remove the edge (by reference) from
the linked list

Attempt 2: Linked Edge List

```
class DirectedGraphV2[V, E] extends Graph[V, E] {  
  val edges = DoublyLinkedList[Edge]()  
  
  def removeEdge(edge: Edge): Unit = {  
    edges.remove(edge.node)  
  }  
  /* ... */  
}
```

Remove the edge (by reference) from
the linked list

What is the complexity?

Attempt 2: Linked Edge List

```
class DirectedGraphV2[V, E] extends Graph[V, E] {  
  val edges = DoublyLinkedList[Edge]()  
  
  def removeEdge(edge: Edge): Unit = {  
    edges.remove(edge.node)  
  }  
  /* ... */  
}
```

Remove the edge (by reference) from
the linked list

What is the complexity? $\Theta(1)$

Attempt 2: Linked Edge List

```
class DirectedGraphV2[V, E] extends Graph[V, E] {  
  val vertices = DoublyLinkedList[Vertex]()  
  
  def removeVertex(vertex: Vertex): Unit = {  
    vertices.remove(vertex.node)  
  }  
  /* ... */  
}
```

Attempt 2: Linked Edge List

```
class DirectedGraphV2[V, E] extends Graph[V, E] {  
  val vertices = DoublyLinkedList[Vertex]()  
  
  def removeVertex(vertex: Vertex): Unit = {  
    vertices.remove(vertex.node)  
  }  
  /* ... */  
}
```

What if there's an edge to/from the vertex?

Attempt 2: Linked Edge List

```
class DirectedGraphV2[V, E] extends Graph[V, E] {  
  val vertices = DoublyLinkedList[Vertex]()  
  
  def removeVertex(vertex: Vertex): Unit = {  
    vertices.remove(vertex.node)  
    for(edge <- vertex.incidentEdges){  
      removeEdge(edge)  
    }  
  }  
  /* ... */  
}
```

Attempt 2: Linked Edge List

```
class DirectedGraphV2[V, E] extends Graph[V, E] {  
  val vertices = DoublyLinkedList[Vertex]()  
  
  def removeVertex(vertex: Vertex): Unit = {  
    vertices.remove(vertex.node)  
    for(edge <- vertex.incidentEdges) {  
      removeEdge(edge)  
    }  
  }  
  /* ... */  
}
```

Remove the vertex (by reference) from the linked list, and then all remove all incident edges (by reference)

Attempt 2: Linked Edge List

```
class DirectedGraphV2[V, E] extends Graph[V, E] {  
  val vertices = DoublyLinkedList[Vertex]()  
  
  def removeVertex(vertex: Vertex): Unit = {  
    vertices.remove(vertex.node)  
    for(edge <- vertex.incidentEdges) {  
      removeEdge(edge)  
    }  
  }  
  /* ... */  
}
```

Remove the vertex (by reference) from the linked list, and then all remove all incident edges (by reference)

What is the complexity?

Attempt 2: Linked Edge List

```
class DirectedGraphV2[V, E] extends Graph[V, E] {  
  val vertices = DoublyLinkedList[Vertex]()  
  
  def removeVertex(vertex: Vertex): Unit = {  
    vertices.remove(vertex.node)  
    for(edge <- vertex.incidentEdges) {  
      removeEdge(edge)  
    }  
  }  
  /* ... */  
}
```

Remove the vertex (by reference) from the linked list, and then all remove all incident edges (by reference)

What is the complexity? $O(1) + O(T_{\text{incidentEdges}}(n,m))$

Attempt 2: Linked Edge List

```
class DirectedGraphV2[V, E] extends Graph[V, E] {  
  val vertices = DoublyLinkedList[Vertex]()  
  
  def removeVertex(vertex: Vertex): Unit = {  
    vertices.remove(vertex.node)  
    for(edge <- vertex.incidentEdges) {  
      removeEdge(edge)  
    }  
  }  
  /* ... */  
}
```

*How do we figure out what
edges are incident?*

What is the complexity? $O(1) + O(T_{\text{incidentEdges}}(n,m))$

Attempt 2: Linked Edge List

```
class DirectedGraphV2[V, E] extends Graph[V, E] {  
  val vertices = DoublyLinkedList[Vertex]()  
  val edges = DoublyLinkedList[Edge]()  
  class Vertex(label: V) = {  
    /* ... */  
    def outEdges =  
      edges.filter { _.orig = this }  
  
    def inEdges =  
      edges.filter { _.dest = this }  
  }  
  /* ... */  
}
```

Attempt 2: Linked Edge List

```
class DirectedGraphV2[V, E] extends Graph[V, E] {  
  val vertices = DoublyLinkedList[Vertex]()  
  val edges = DoublyLinkedList[Edge]()  
  class Vertex(label: V) = {  
    /* ... */  
    def outEdges =  
      edges.filter { _.orig == this }  
  
    def inEdges =  
      edges.filter { _.dest == this }  
  }  
  /* ... */  
}
```



What is the complexity?

Attempt 2: Linked Edge List

```
class DirectedGraphV2[V, E] extends Graph[V, E] {  
  val vertices = DoublyLinkedList[Vertex]()  
  val edges = DoublyLinkedList[Edge]()  
  class Vertex(label: V) = {  
    /* ... */  
    def outEdges =  
      edges.filter { _.orig = this }  
  
    def inEdges =  
      edges.filter { _.dest = this }  
  }  
  /* ... */  
}
```

What is the complexity? $O(m) = O(n^2)$

Edge List Summary

- `addEdge`, `addVertex`:
- `removeEdge`:
- `removeVertex`:
- `vertex.incidentEdges`:

Edge List Summary

- `addEdge`, `addVertex`: $O(1)$
- `removeEdge`:
- `removeVertex`:
- `vertex.incidentEdges`:

Edge List Summary

- `addEdge`, `addVertex`: $O(1)$
- `removeEdge`: $O(1)$
- `removeVertex`:
- `vertex.incidentEdges`:

Edge List Summary

- `addEdge`, `addVertex`: $O(1)$
- `removeEdge`: $O(1)$
- `removeVertex`: $O(m)$
- `vertex.incidentEdges`:

Edge List Summary

- `addEdge`, `addVertex`: $O(1)$
- `removeEdge`: $O(1)$
- `removeVertex`: $O(m)$
- `vertex.incidentEdges`: $O(m)$

Edge List Summary

- `addEdge`, `addVertex`: $O(1)$
- `removeEdge`: $O(1)$
- `removeVertex`: $O(m)$
- `vertex.incidentEdges`: $O(m)$
- `vertex.edgeTo`: $O(m)$

Edge List Summary

- `addEdge`, `addVertex`: $O(1)$
- `removeEdge`: $O(1)$
- `removeVertex`: $O(m)$
- `vertex.incidentEdges`: $O(m)$
- `vertex.edgeTo`: $O(m)$
- **Space Used**: $O(n) + O(m)$

Edge List Summary

LinkedList[Vertex]

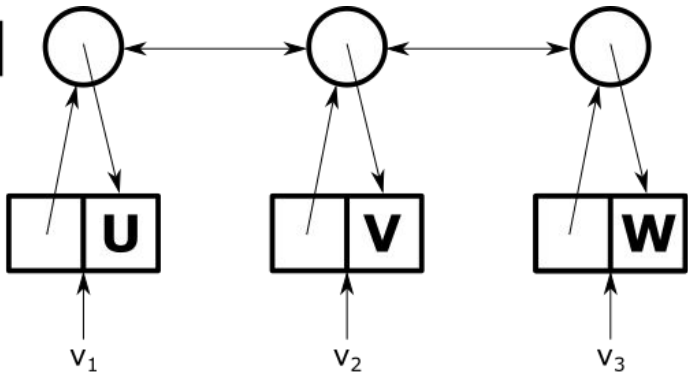

Vertex

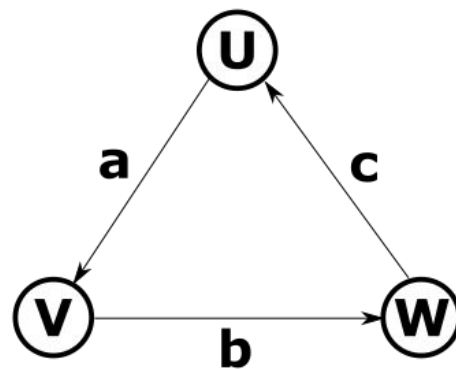

Edge

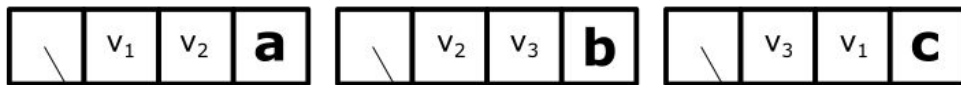

LinkedList[Edge]



How can we improve?

How can we improve?

Idea: Store the in/out edges for each vertex!

Attempt 3: Adjacency List

```
class DirectedGraphV3[V, E] extends Graph[V, E] {  
  val vertices = DoublyLinkedList[Vertex]()  
  
  class Vertex(label: V) = {  
    var node: DoublyLinkedList[Vertex].Node = null  
    val inEdges = DoublyLinkedList[Edge]()  
    val outEdges = DoublyLinkedList[Edge]()  
    /* ... */  
  }  
  /* ... */  
}
```

Attempt 3: Adjacency List

```
class DirectedGraphV3[V, E] extends Graph[V, E] {  
  val vertices = DoublyLinkedList[Vertex]()  
  
  class Vertex(label: V) = {  
    var node: DoublyLinkedList[Vertex].Node = null  
    val inEdges = DoublyLinkedList[Edge]()  
    val outEdges = DoublyLinkedList[Edge]()  
    /* ... */  
  }  
  /* ... */  
}
```

Store linked lists of incident
edges to this vertex

Attempt 3: Adjacency List

```
class DirectedGraphV3[V, E] extends Graph[V, E] {  
  /* ... */  
  def addEdge(orig: Vertex, dest: Vertex, label: E): Vertex = {  
    val edge = new Edge(orig, dest, label)  
    val node = edges.append(vertex)  
    edge.node = node  
    orig.outEdges.append(edge)  
    dest.inEdges.append(edge)  
    return edge  
  }  
  /* ... */  
}
```

Attempt 3: Adjacency List

```
class DirectedGraphV3[V, E] extends Graph[V, E] {  
  /* ... */  
  def addEdge(orig: Vertex, dest: Vertex, label: E): Vertex = {  
    val edge = new Edge(orig, dest, label)  
    val node = edges.append(vertex)  
    edge.node = node  
    orig.outEdges.append(edge)  
    dest.inEdges.append(edge)  
    return edge  
  }  
  /* ... */  
}
```

Also add our edge to the
adjacency lists

Attempt 3: Adjacency List

```
class DirectedGraphV3[V, E] extends Graph[V, E] {  
  /* ... */  
  def addEdge(orig: Vertex, dest: Vertex, label: E): Vertex = {  
    val edge = new Edge(orig, dest, label)  
    val node = edges.append(vertex)  
    edge.node = node  
    orig.outEdges.append(edge)  
    dest.inEdges.append(edge)  
    return edge  
  }  
  /* ... */  
}
```

Also add our edge to the
adjacency lists

What is the complexity?

Attempt 3: Adjacency List

```
class DirectedGraphV3[V, E] extends Graph[V, E] {  
  /* ... */  
  def addEdge(orig: Vertex, dest: Vertex, label: E): Vertex = {  
    val edge = new Edge(orig, dest, label)  
    val node = edges.append(vertex)  
    edge.node = node  
    orig.outEdges.append(edge)  
    dest.inEdges.append(edge)  
    return edge  
  }  
  /* ... */  
}
```

Also add our edge to the
adjacency lists

What is the complexity? $\Theta(1)$

Attempt 3: Adjacency List

```
class DirectedGraphV3[V, E] extends Graph[V, E] {  
  /* ... */  
  def removeEdge(edge: Edge): Unit = {  
    edges.remove(edge.node)  
    edge.orig.outEdges.subtractOne(edge)  
    edge.dest.inEdges.subtractOne(edge)  
  }  
  /* ... */  
}
```

Attempt 3: Adjacency List

```
class DirectedGraphV3[V, E] extends Graph[V, E] {  
  /* ... */  
  def removeEdge(edge: Edge): Unit = {  
    edges.remove(edge.node)  
    edge.orig.outEdges.subtractOne(edge)  
    edge.dest.inEdges.subtractOne(edge)  
  }  
  /* ... */  
}
```

Remove the edges from our
adjacency lists...?

Attempt 3: Adjacency List

```
class DirectedGraphV3[V, E] extends Graph[V, E] {  
  /* ... */  
  def removeEdge(edge: Edge): Unit = {  
    edges.remove(edge.node)  
    edge.orig.outEdges.subtractOne(edge)  
    edge.dest.inEdges.subtractOne(edge)  
  }  
  /* ... */  
}
```

Remove the edges from our
adjacency lists...?

What is the complexity?

Attempt 3: Adjacency List

```
class DirectedGraphV3[V, E] extends Graph[V, E] {  
  /* ... */  
  def removeEdge(edge: Edge): Unit = {  
    edges.remove(edge.node)  
    edge.orig.outEdges.subtractOne(edge)  
    edge.dest.inEdges.subtractOne(edge)  
  }  
  /* ... */  
}
```

Remove the edges from our
adjacency lists...?

What is the complexity? $O(\text{deg}(\text{orig})) + O(\text{deg}(\text{dest}))$

Attempt 4: Adjacency List

```
class DirectedGraphV4[V, E] extends Graph[V, E] {  
  /* ... */  
  class Edge(orig: Vertex, dest: Vertex, label: E) = {  
    var node: DoublyLinkedList[Edge].Node = null  
    var origNode: DoublyLinkedList[Edge].Node = null  
    var destNode: DoublyLinkedList[Edge].Node = null  
    /* ... */  
  }  
  /* ... */  
}
```

Attempt 4: Adjacency List

```
class DirectedGraphV4[V, E] extends Graph[V, E] {  
  /* ... */  
  class Edge(orig: Vertex, dest: Vertex, label: E) = {  
    var node: DoublyLinkedList[Edge].Node = null  
    var origNode: DoublyLinkedList[Edge].Node = null  
    var destNode: DoublyLinkedList[Edge].Node = null  
    /* ... */  
  }  
  /* ... */  
}
```

Let's save references for each
adjacency list!

Attempt 4: Adjacency List

```
class DirectedGraphV4[V, E] extends Graph[V, E] {  
  /* ... */  
  def addEdge(orig: Vertex, dest: Vertex, label: E): Vertex = {  
    val edge = new Edge(orig, dest, label)  
    val node = edges.append(vertex)  
    edge.node = node  
    edge.origNode = orig.outEdges.append(edge)  
    edge.destNode = dest.inEdges.append(edge)  
    return edge  
  }  
  /* ... */  
}
```

Attempt 4: Adjacency List

```
class DirectedGraphV4[V, E] extends Graph[V, E] {  
  /* ... */  
  def addEdge(orig: Vertex, dest: Vertex, label: E): Vertex = {  
    val edge = new Edge(orig, dest, label)  
    val node = edges.append(vertex)           Save our references when  
    edge.node = node                          adding an edge  
    edge.origNode = orig.outEdges.append(edge)  
    edge.destNode = dest.inEdges.append(edge)  
    return edge  
  }  
  /* ... */  
}
```

Attempt 4: Adjacency List

```
class DirectedGraphV4[V, E] extends Graph[V, E] {  
  /* ... */  
  def addEdge(orig: Vertex, dest: Vertex, label: E): Vertex = {  
    val edge = new Edge(orig, dest, label)  
    val node = edges.append(vertex)           Save our references when  
    edge.node = node                          adding an edge  
    edge.origNode = orig.outEdges.append(edge)  
    edge.destNode = dest.inEdges.append(edge)  
    return edge  
  }  
  /* ... */  
}
```

What is the complexity?

Attempt 4: Adjacency List

```
class DirectedGraphV4[V, E] extends Graph[V, E] {  
  /* ... */  
  def addEdge(orig: Vertex, dest: Vertex, label: E): Vertex = {  
    val edge = new Edge(orig, dest, label)  
    val node = edges.append(vertex)           Save our references when  
    edge.node = node                          adding an edge  
    edge.origNode = orig.outEdges.append(edge)  
    edge.destNode = dest.inEdges.append(edge)  
    return edge  
  }  
  /* ... */  
}
```

What is the complexity? $\Theta(1)$

Attempt 4: Adjacency List

```
class DirectedGraphV4[V, E] extends Graph[V, E] {  
  /* ... */  
  def removeEdge(edge: Edge): Unit = {  
    edges.remove(edge.node)  
    edge.orig.outEdges.remove(edge.origNode)  
    edge.dest.inEdges.remove(edge.destNode)  
  }  
  /* ... */  
}
```

Attempt 4: Adjacency List

```
class DirectedGraphV4[V, E] extends Graph[V, E] {  
  /* ... */  
  def removeEdge(edge: Edge): Unit = {                                Remove by reference!  
    edges.remove(edge.node)  
    edge.orig.outEdges.remove(edge.origNode)  
    edge.dest.inEdges.remove(edge.destNode)  
  }  
  /* ... */  
}
```

Attempt 4: Adjacency List

```
class DirectedGraphV4[V, E] extends Graph[V, E] {  
  /* ... */  
  def removeEdge(edge: Edge): Unit = {                                Remove by reference!  
    edges.remove(edge.node)  
    edge.orig.outEdges.remove(edge.origNode)  
    edge.dest.inEdges.remove(edge.destNode)  
  }  
  /* ... */  
}
```

What is the complexity?

Attempt 4: Adjacency List

```
class DirectedGraphV4[V, E] extends Graph[V, E] {  
  /* ... */  
  def removeEdge(edge: Edge): Unit = {  
    edges.remove(edge.node)  
    edge.orig.outEdges.remove(edge.origNode)  
    edge.dest.inEdges.remove(edge.destNode)  
  }  
  /* ... */  
}
```

Remove by reference!

What is the complexity? $\Theta(1)$

Attempt 4: Adjacency List

```
class DirectedGraphV4[V, E] extends Graph[V, E] {  
  /* ... */  
  def removeVertex(vertex: Vertex): Unit = {  
    vertices.remove(vertex.node)  
    for(edge <- vertex.incidentEdges){  
      removeEdge(edge)  
    }  
  }  
  /* ... */  
}
```

Attempt 4: Adjacency List

```
class DirectedGraphV4[V, E] extends Graph[V, E] {  
  /* ... */  
  def removeVertex(vertex: Vertex): Unit = {  
    vertices.remove(vertex.node)  
    for(edge <- vertex.incidentEdges){  
      removeEdge(edge)  
    }  
  }  
  /* ... */  
}
```

What is the complexity?

Attempt 4: Adjacency List

```
class DirectedGraphV4[V, E] extends Graph[V, E] {  
  /* ... */  
  def removeVertex(vertex: Vertex): Unit = {  
    vertices.remove(vertex.node)  
    for(edge <- vertex.incidentEdges){  
      removeEdge(edge)  
    }  
  }  
  /* ... */  
}
```

What is the complexity? $O(\text{deg}(\text{vertex}))$

Adjacency List Summary

- `addEdge`, `addVertex`:
- `removeEdge`:
- `removeVertex`:
- `vertex.incidentEdges`:
- `vertex.edgeTo`:
- **Space Used:**

Adjacency List Summary

- `addEdge`, `addVertex`: $O(1)$
- `removeEdge`:
- `removeVertex`:
- `vertex.incidentEdges`:
- `vertex.edgeTo`:
- **Space Used:**

Adjacency List Summary

- `addEdge`, `addVertex`: $O(1)$
- `removeEdge`: $O(1)$
- `removeVertex`:
- `vertex.incidentEdges`:
- `vertex.edgeTo`:
- **Space Used:**

Adjacency List Summary

- `addEdge`, `addVertex`: $O(1)$
- `removeEdge`: $O(1)$
- `removeVertex`: $O(\text{deg}(\text{vertex}))$
- `vertex.incidentEdges`:
- `vertex.edgeTo`:
- **Space Used:**

Adjacency List Summary

- `addEdge`, `addVertex`: $O(1)$
- `removeEdge`: $O(1)$
- `removeVertex`: $O(\text{deg}(\text{vertex}))$
- `vertex.incidentEdges`: $O(\text{deg}(\text{vertex}))$
- `vertex.edgeTo`:
- **Space Used:**

Adjacency List Summary

- `addEdge`, `addVertex`: $O(1)$
- `removeEdge`: $O(1)$
- `removeVertex`: $O(\text{deg}(\text{vertex}))$
- `vertex.incidentEdges`: $O(\text{deg}(\text{vertex}))$
- `vertex.edgeTo`: $O(\text{deg}(\text{vertex}))$
- **Space Used:**

Adjacency List Summary

- `addEdge`, `addVertex`: $O(1)$
- `removeEdge`: $O(1)$
- `removeVertex`: $O(\text{deg}(\text{vertex}))$
- `vertex.incidentEdges`: $O(\text{deg}(\text{vertex}))$
- `vertex.edgeTo`: $O(\text{deg}(\text{vertex}))$
- **Space Used**: $O(n) + O(m)$

Adjacency Matrix

		<u>Destination</u>		
		U	V	W
<u>Origin</u>	U	-	<i>a</i>	-
	V	-	-	<i>b</i>
	W	<i>c</i>	-	-

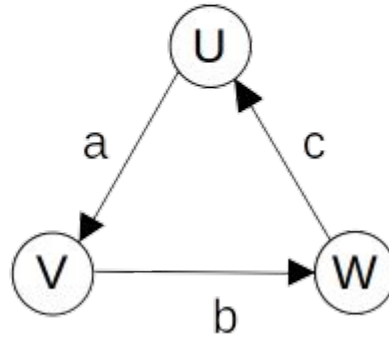

Adjacency Matrix Summary

- `addEdge`, `removeEdge`:
- `addVertex`, `removeVertex`:
- `vertex.incidentEdges`:
- `vertex.edgeTo`:
- **Space Used:**

Adjacency Matrix Summary

- `addEdge`, `removeEdge`: $O(1)$
- `addVertex`, `removeVertex`:
- `vertex.incidentEdges`:
- `vertex.edgeTo`:
- **Space Used:**

Adjacency Matrix Summary

- `addEdge`, `removeEdge`: $O(1)$
- `addVertex`, `removeVertex`: $O(n^2)$
- `vertex.incidentEdges`:
- `vertex.edgeTo`:
- **Space Used:**

Adjacency Matrix Summary

- `addEdge`, `removeEdge`: $O(1)$
- `addVertex`, `removeVertex`: $O(n^2)$
- `vertex.incidentEdges`: $O(n)$
- `vertex.edgeTo`:
- **Space Used:**

Adjacency Matrix Summary

- `addEdge`, `removeEdge`: $O(1)$
- `addVertex`, `removeVertex`: $O(n^2)$
- `vertex.incidentEdges`: $O(n)$
- `vertex.edgeTo`: $O(1)$
- **Space Used:**

Adjacency Matrix Summary

- `addEdge`, `removeEdge`: $O(1)$
- `addVertex`, `removeVertex`: $O(n^2)$
- `vertex.incidentEdges`: $O(n)$
- `vertex.edgeTo`: $O(1)$
- **Space Used**: $O(n^2)$